

Application

volumetric / gravimetric feeding of solids.

- Pellets Micro-Pellets Grind Powder Fibers

SCHOLZ FLEX130

Single-Screw Feeder with flexible hopper.

- separate paddle-drive as standard
- flexibly adjustable paddles (stroke, distance, size)
- PU-hopper with stable frame for easy handling
- Made in Germany

Dosing-capacity of the SCHOLZ FLEX-Series

| kg/h (bei 0,5kg/l) | 0,1 | 1 | 5 | 10 | 50 | 100 | 500 | 1.000 | 5.000 | 10.000 | 25.000 |
|--------------------|-----|---|---|----|----|-----|-----|-------|-------|--------|--------|
| FLEX50 | | | | | | | | | | | |
| FLEX80 | | | | | | | | | | | |
| FLEX130 | | | | | | | | | | | |

- Screws: \varnothing 100mm to \varnothing 125mm in full-blade / spiral / with core / double-helix / notched / special / coated
- Tube-Outlet: \varnothing 100mm to \varnothing 125mm horizontal / vertical / with shutter
- Hopper: 100 Liter in standard / FDA / acid / high-temp / ATEX
- Add. Hopper: 60 to 300 Liter round / square, expandable
- Lid: for manual / automatic refilling / flap-lid / plexiglass / for conveyors
- Options: Agitator / ATEX / run control / outlet-compensation
- Material: Stainless Steel 1.4301, Hopper Polyurethan-based mixture
- Weight: appr. 115kg (without hoppers)
- Dimensions: 700x700x540mm (DxWxH)
- Gear-Motor: A $i=5,1$ $\Delta 230/Y400V$; 0,99/1,71A; 0,37kW; 1425U/min; 50Hz
 B $i=17,8$ $\Delta 230/Y400V$; 0,99/1,71A; 0,37kW; 1425U/min; 50Hz
 C $i=60,1$ $\Delta 230/Y400V$; 0,62/1,07A; 0,18kW; 1400U/min; 50Hz
- Paddle-Motor: $i=58$ $\Delta 230/Y400V$; 0,71/0,41A; 0,09kW; 1360U/min; 50Hz

Loss-in-weight-Feeder TITAN

In combination with a SCHOLZ BASIC platform scale, you have a gravimetric feeding-scale.

- Scale: **BASIC700**
- Capacity: 300 / 1000kg
- Platform: 700 x 700mm
- Dimensions: 790 x 700 x 150mm (DxWxH)
- Material : Alu / Stainless Steel
- Execution: plug & play
- Own weight: 40kgs

The SCHOLZ-CON-TRUST control system enables single- and multi-component operation.



FLEX130 with 300-Liter-hopper and vertical tube-outlet

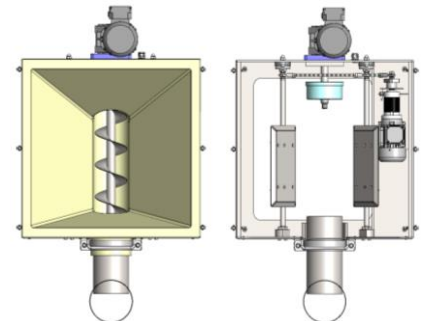

Top view with / without PU-hopper



FLEX130 with 65+150-Liter-hoppers and vertical tube-outlet placed on Platform scale BASIC700

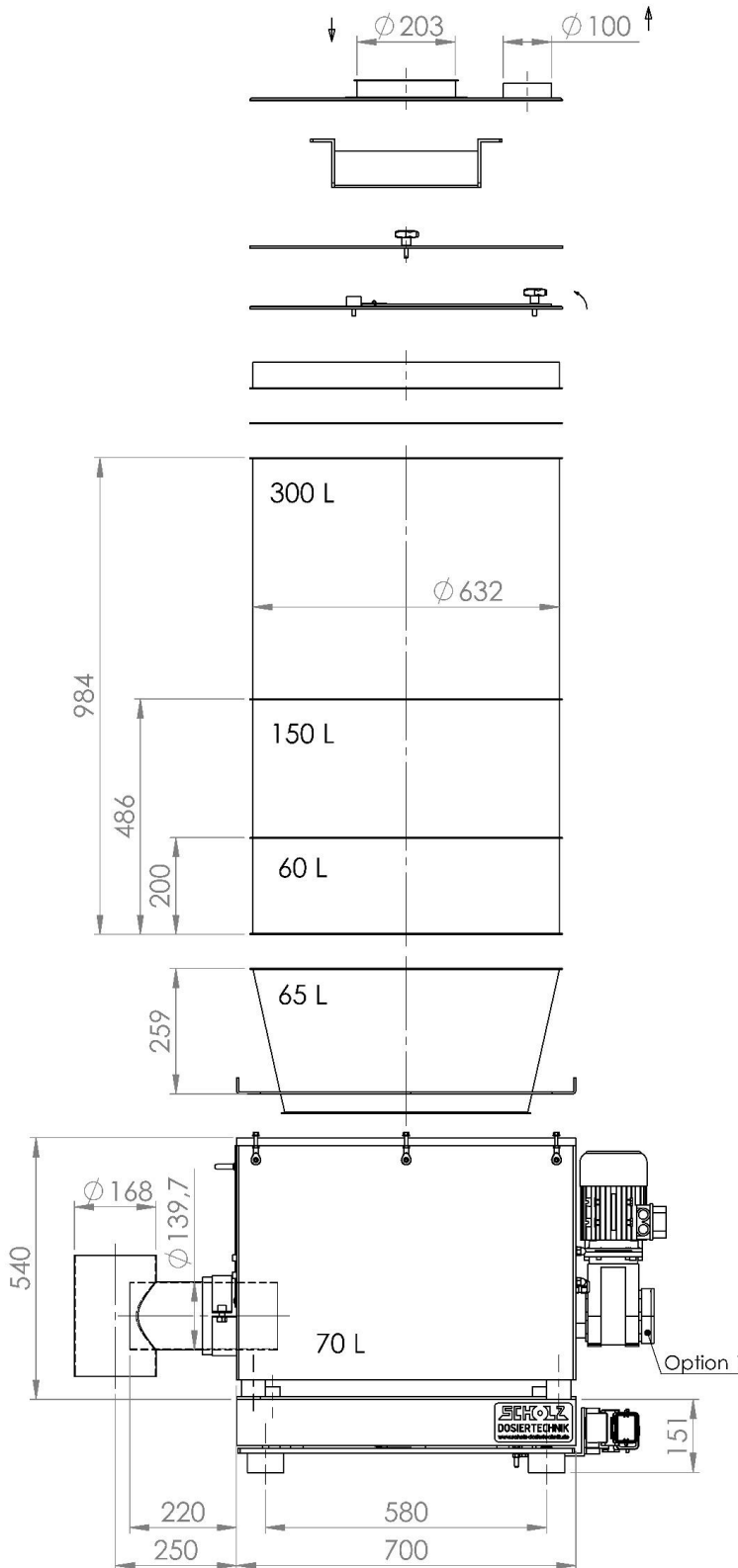

AUTO LID

ALR-6 4,5 kg

GUIDE ANGLE

GA 1,3 kg

MANUAL LID

MLR-6 4,4 kg

FLAP LID

FLR-6 5,3 kg

SAFETY GRID

GAR-6 1,9 kg
SGR-6 1,2 kg

BASIC HOPPER

RH-300-610 30,0 kg
RH-150-65 16,0 kg
RH-60-62 6,0 kg

BASIC FLANGE

BF-630 20,0 kg

FEEDER

FLEX130 115,0 kg

Option 1
FLEX130-RC 0,5 kg
RUN CONTROL

SCALE

BASIC700 20,0 kg

Differential-Dosierwaage TITAN
Loss-in-Weight-Feeder TITAN